

SOLATHERM

Power Control Equipment



Model:

PV360 Heating Only
Power Control Equipment (PCE)

PV DIRECT 
Ready

PV DC Electric Hot Water

Owner Manual

1/52 Barnett Ave, Glynde, SA 5070
Phone 08 8337 8881
www.solatherm.com.au



ATTENTION

The Solatherm controller and water heater vessel must be installed by an authorised person and the installation must comply with all the relevant Australian Standards, local and industry regulations.



ATTENTION

This appliance is not intended for use by persons (including children) with reduced physical, sensory or mental capabilities, or lack of experience and knowledge, unless they have been given supervision or instruction concerning use of the appliance by a person responsible for their safety.

Children should be supervised to ensure that they do not play with the appliance.



WARNING

Once installed the hot water tank is powered by TWO SOURCES of Power Supply, both sources must be isolated before working on the appliance.



Before commencement of any service work on the hot water circuit, including work that partially or completely drains the storage vessel, ensure all electrical supplies, the Photovoltaic array and AC connection have been disconnected as per the System Shutdown procedure in this manual.



PV ARRAY WARNING

When the photovoltaic array is exposed to light, it supplies a d.c. voltage to the PCE.



WARNING

The controller is only to be connected to a hot water cylinder specifically designed and configured for use with the Solatherm DC controller (P.C.E.). It is not for retrofit.



WARNING

If the equipment is used in a manner not specified by the manufacturer, the protection provided by the equipment may be impaired.



CONNECTION WARNING

Solatherm Photo Voltaic Over Temperature Cut Out (PVOTC) must be installed in the power supply feed to the DC heating element.



WARNING

DANGER the operation of the PV (DC) thermal cut out indicates a possibly dangerous situation. The water heater must be inspected by a qualified person and the PV-OTC (PV thermal cut out) replaced.



WARNING

DANGER the operation of the 240V AC thermal cut out indicates a possibly dangerous situation. Do not reset the 240V AC thermal cut out until the water heater has been serviced by a qualified person.



PV ARRAY WARNING

Maximum array power of 3.84kW must not be exceeded. Current must not exceed 22 Amps, array design must not exceed 2 strings. Voltage must not exceed 270V, String length must not exceed 6 panels.

Max power must not be exceeded.

3.84kW can be either 270V @14.2A or 174V @ 22.0A or in between.

$P=IR$ (Volts x Current), 3840W must not be exceeded.



WARNING

The controller has no user serviceable parts. Opening the cover will void all warranty and may expose dangerous voltages.

Removal of the covers on the storage water vessel will expose live electrical wiring. Covers must only be removed by an authorised service person and only once dual supply power has been isolated.



ATTENTION

Ensure all glands from the control box are firmly tightened to ensure ingress protection.



ELECTRICAL WARNING

All electrical work and permanent wiring must be carried out by a qualified person and in accordance with all current relevant Australian installation standards and local authority requirements.

Means for disconnection must be incorporated in the fixed wiring in accordance with the wiring rules.

All electrical connections must be terminated before switching any component on. The power to the Solatherm solar control unit and water heater must NOT be switched on until the water heater is completely filled with water and all air bled from the system.



WATER CONNECTIONS FOR STORAGE VESSEL

Please ensure all plumbing installation work is carried out in accordance with AS3500 and that a non-return valve is installed in the incoming water line. Maximum inlet pressure 700kPa, minimum inlet pressure 350 kPa.

A pressure relief valve must be fitted in accordance with AS 3500, rating 850kPa 10kW. A discharge pipe must be connected to the device and be installed in a continuously downward direction and in a frost-free environment and the end must be left open to atmosphere.



DANGER

Failure to operate the relief valve easing gear at least once every six months may result in the water heater exploding. Water may drip from the discharge pipe but continuous leakage from the valve may indicate a problem with the water heater, please have your water heater serviced by a qualified person.

If the water supply pressure exceeds the rated pressure, a pressure reducing valve is to be fitted in the installation.

The water may drip from the discharge pipe of the pressure-relief device and that this pipe must be left open to the atmosphere;

The pressure-relief device is to be operated regularly to remove lime deposits and to verify that it is not blocked;

The water heater can be drained by disconnecting the water inlet.

Symbol Glossary

Symbols Used			
	Refer to the operating instructions		Caution, risk of danger
	Protective conductor terminal		Caution, risk of electric shock
	Positive conductor		Negative conductor

Contents

Symbol Glossary	3
Contents	4
About	5
Display	6
Basic System Configuration	7
Start-up Procedure.....	8
System Shutdown.....	8
Maintenance	8
Frequently Asked Questions.....	9
Troubleshooting	10
Installation Instructions.....	11
Wiring Diagram - Controller	11
On the Ground.....	11
Wall mounting PCE controller	12
Mounting Clearances and Mount Point Locations.....	13
Connection - Controller to Storage Water Vessel - DC	14
Wiring Diagram - PVOTC - Element.....	15
Connection - Main Array Input.....	16
Connection - Boost Element - AC	17
ON THE ROOF	18
Panel Configuration.....	18
Commissioning Start Up.....	19
Shut down Procedure.....	19
Warranty.....	20
Warranty Definitions.....	20
Warranty Conditions	20
Warranty Exclusions.....	21
Commissioning	22
System Information - Form A	22
System Diagram.....	24
Technical Data	25

About

The Solatherm control unit regulates DC electricity generated by a photovoltaic array and applies it to a resistive heating element, located in a storage hot water vessel, to generate hot water. The microprocessor constantly monitors the water temperature in the storage vessel and energizes the heating element when sufficient power is available from the array and the water stored in the vessel is below the set temperature. (Factory set temperature 60^o or 70^o Celsius) When the temperature is reached the unit will turn the element off until the water temperature falls.

Once the water is up to temperature the controller monitors the temperature of the stored water to ensure maximum hot water is maintained.

Solatherm Control Units are independent from the grid and require no mains power connection to operate, hence, the unit will only operate and display user information when there is sufficient energy from the sun. It is normal for the LCD display and lights to flicker or not fully display in low light conditions.

During periods of low solar input where there is insufficient power available to heat the stored water to 60^oC the independent 240V AC boost element will top up the temperature of the water in the storage vessel.

NB: Generally the independent AC boost element is connected to an off peak (controlled load) power supply. If only peak is available it is recommended to install a din rail timer and set a heating period during the early evening and/or early morning depending on the household demand. If the water in the storage vessel is higher than the 60^oC thermostat setting the unit will not draw any power as there is no need. If the water is below 60^oC during the set periods the boost element will top up the temperature to ensure hot water is available. The boost element heats approximately 125L of water. Connection via a timer will maximise solar gain during the day, minimise energy consumption and allow for ease of use. High usage households may require extended boost periods or continuous mains connection to meet high demand.

Display

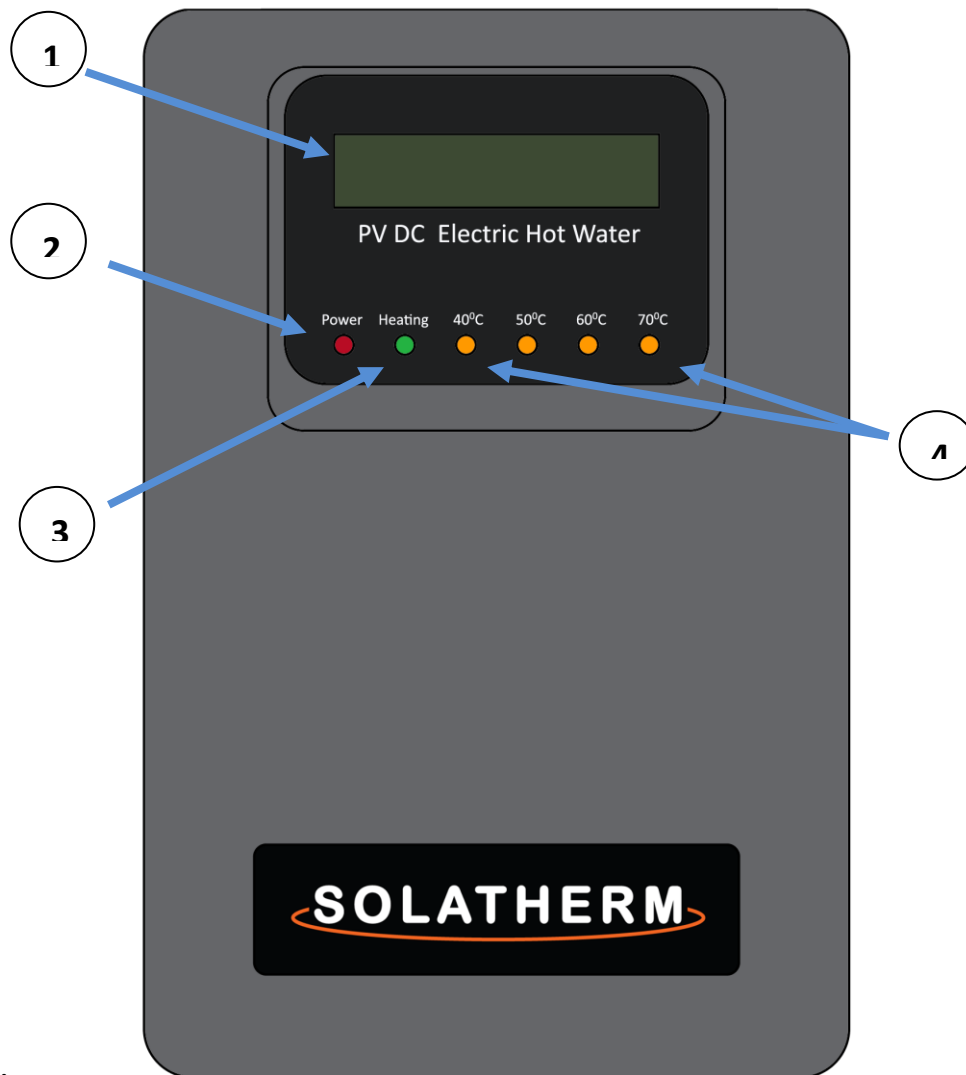

Figure 1.

Solatherm Control Units are independent from the grid and require no mains power connection to operate, hence, the unit will only operate and display user information when there is sufficient energy from the sun. It is normal for the LCD display and lights to flicker or not fully display in low light conditions.

1	LCD Display	Scrolling display showing the array voltage and when the heating element is activated, the current and power. The second line shows the kW/h consumed for the day and the total kW/h consumption.
2	Power	LED illuminated red when the main array is connected and supplying power to the unit. In low light conditions this light may be the only LED lit or flashing.
3	Heating	LED illuminated green when the controller has energized the heating element.
4	40 ^o -70 ^o C	LED's illuminated orange - an approximate indication of the average temperature of the water stored in the storage vessel.

Basic System Configuration

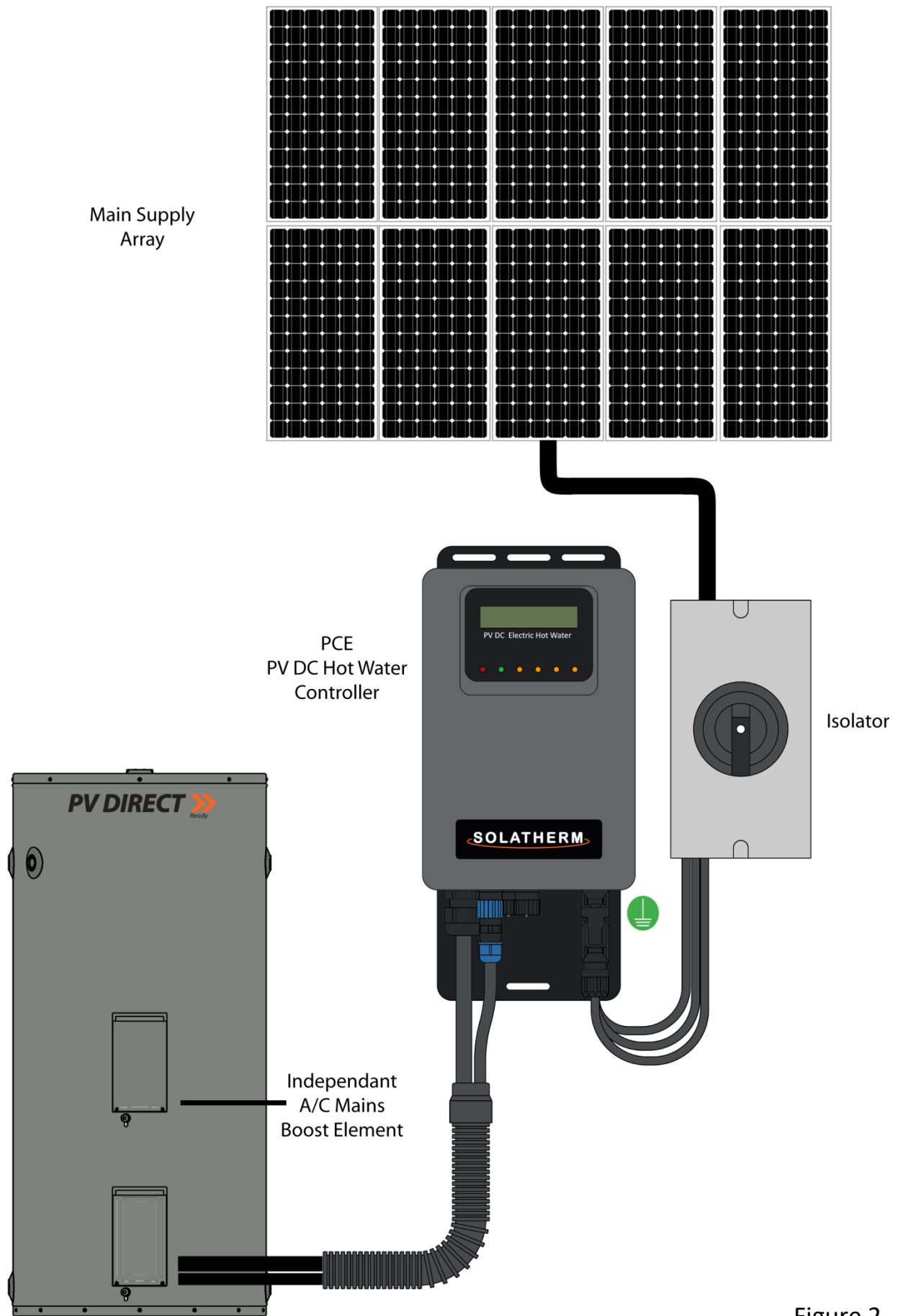

Figure 2.

Start-up Procedure

NOTE: ENSURE HOT WATER VESSEL IS COMPLETELY FILLED WITH WATER BEFORE COMENCING START UP PROCEDURE.

1. Turn on Isolator. RED LED POWER LIGHT SHOULD BE ON. The LCD will illuminate and start to indicate incoming power (providing supply voltage is over 40 Volts). The controller should show start up information as it runs through a power up test sequence. When test is complete LCD will display system voltage etc.
2. After the start up sequence is complete the green heating LED will light up if sufficient power is available to commence heating. Note: The controller has several built-in time delays of up to 1.5 minutes, to allow for power stabilisation.
3. Turn on 240V AC Booster breaker switch in household fuse box.

System Shutdown

1. Turn off main array isolator (lock switch if required)
2. Controller should now be off, red light and LCD display should be off.
3. Turn off 240V AC Booster isolator and breaker switch in household fuse box.
4. System should now be electrically isolated.

Maintenance

1. There are no serviceable components
2. There is no preventative maintenance required.
3. There are no replaceable parts in the controller.
4. Controller can be wiped with a damp cloth if required.

Frequently Asked Questions

Q: My LCD show 0 Watts but the sun is out?

A:

1. The water in the storage tank is up to temperature.
Dependant on the factory set temperature 60°C or 70°C.
2. During periods of low light intensity such as, early morning, late evening or in dark cloud the main array may not be able to produce the minimum amount of power needed. The controller requires a stable 250 Watts to be available when the element is energized to commence heating. The green heating light will flick approximately every 25 seconds as the controller is testing the amount of power available from the array.

Q: The heating light has been on all day but there is no hot water at the end of the day?

A:

1. The hot water produced has been consumed during the day.
2. If the display is showing 0 Watts with the heating light on there may be a fault with the element or the over temperature cut out. Please contact your installer.

Q: Run out of hot water or warm water only.

A:

1. The hot water produced has been consumed during the day.
2. Not enough solar input during the day. Ensure booster is connected and the AC boost timer settings are correct for the household demand or season.

Troubleshooting

All observations for potential faults need to be conducted in clear daylight conditions.

Observation	Fault
Dim/flickering LCD display & lights	Should this occur in bright sunshine please contact your installer. No Fault if seen in low light conditions. Re-check in brighter conditions. Please see note in Frequently Asked Questions
Flashing temperature lights (Orange LEDs)	Fault with storage water temperature sensor or internal temperature of the enclosure is too high e.g. Controller mounted in full direct sunshine.
No heating light (Green LED)	Element not powered. The controller will only energise the element when there is enough solar energy available and the storage water temperature is below the set point. If clear conditions, the water is cold and no green light appears, contact your installer. Also see FAQ.
Heating light on but no hot water. (Green LED)	Not enough heating time has passed. Allow more time for heating. If light is on but LCD display shows no Power (Watt) figure contact your installer. Possible Element Fault.
Flick of green light (Green LED)	Approximately every 20 seconds. This is the unit testing the power available. A high voltage may display but no current may be available. Not enough sunlight to engage element.
No power light. (Red LED)	Not enough power being produced by the main array. If in clear conditions contact your installer.
No temperature lights (Orange LEDs)	Average water storage temperature is below 32 degrees Celsius

Installation Instructions

Wiring Diagram - Controller

WARNING INCORRECT POLARITY WILL DAMAGE THE CONTROLLER
NO WARRANTY FOR POLARITY DAMAGE

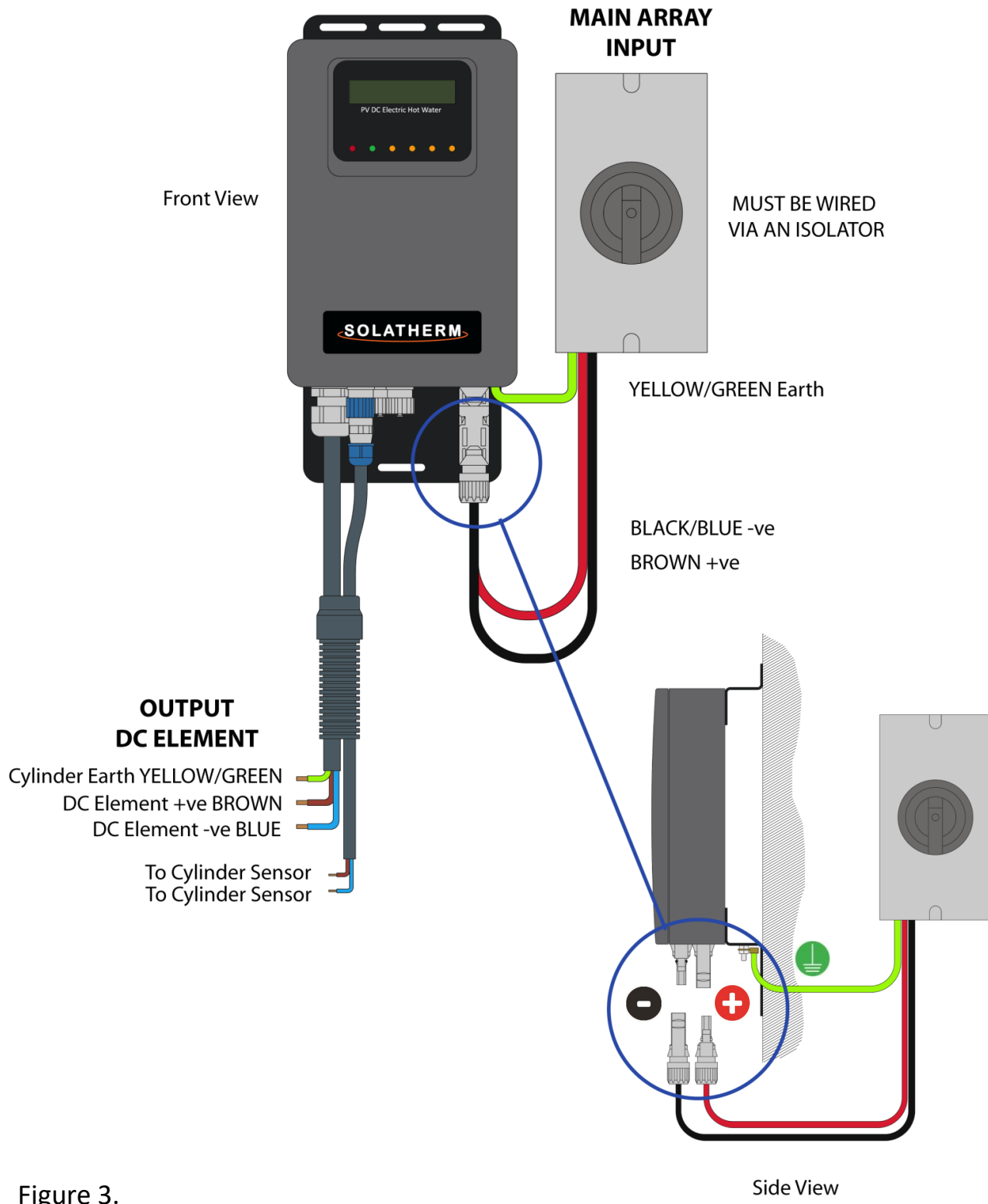

Figure 3.

On the Ground

Wall mounting PCE controller

Choose a suitable location, giving consideration to the following:

1. Vertical wall mount at a height of between 1.5m to 2m above ground level giving consideration to cable length and path to the Hot water vessel and PV main array isolator location.
2. It is important to mount the controller out of the direct sunlight as it will make visual reading of the LCD display difficult.
3. The control box shall be 3 x point screw mounted, via the attached slotted metal brackets at the top and bottom of the controller e.g.: 2 x screws at the top 1 x screw at the bottom. Determine preferred affixing mounting screw method to suit wall substrate. The 2 x top screw holes shall be 80mm apart and the 1 x bottom screw hole shall be 275mm down central to the top 2 x holes and control box. EG: (Like the capital letter **T** 80mm across top & 275mm down).

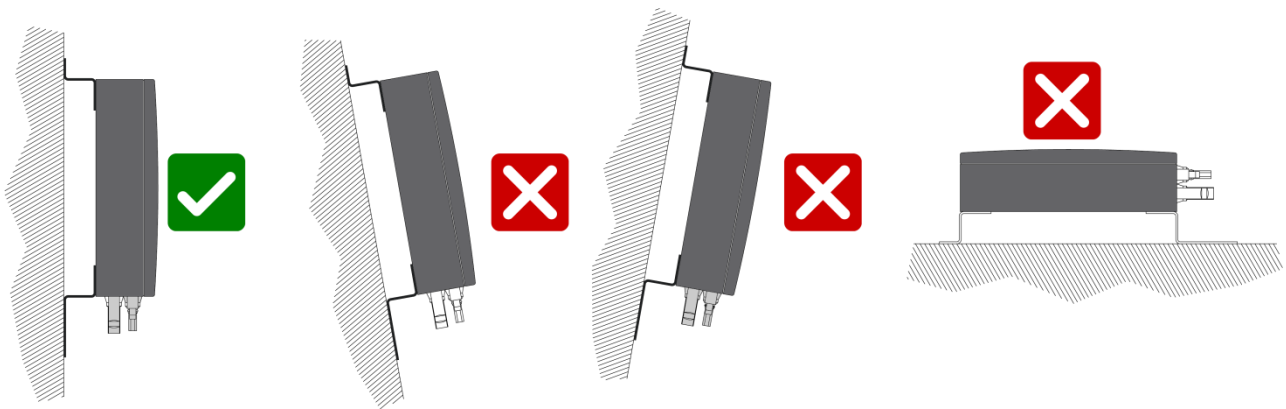

Figure 4.

Continued..

Mounting Clearances and Mount Point Locations

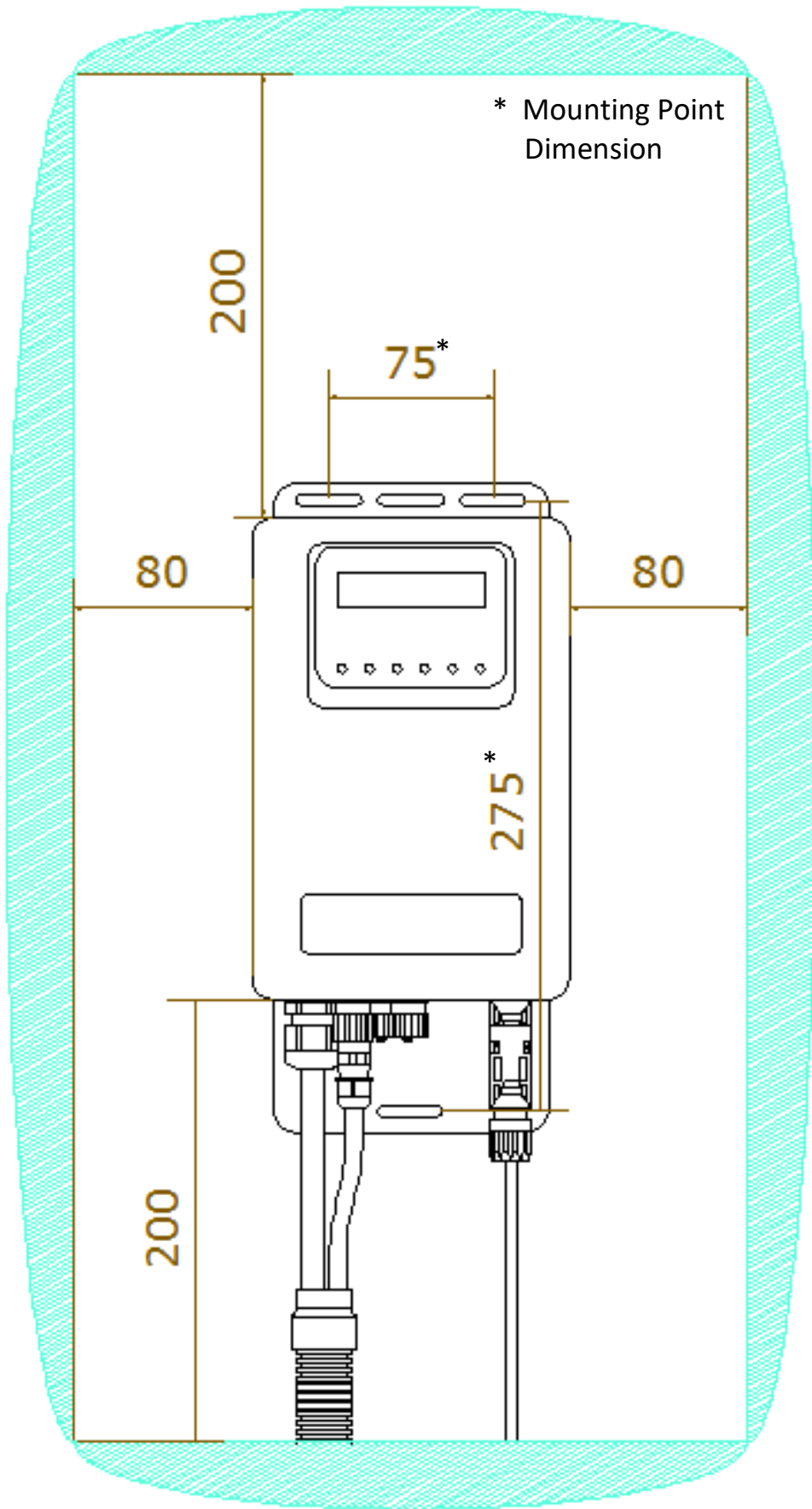

Figure 5.

Connection - Controller to Storage Water Vessel - DC

1. Remove lower DC element cover.
2. Route the 2.5m long flexible element output cable to the bottom element inlet conduit elbow and thread both cables through up into element cavity. It may be necessary to use a wire hook to help thread/ pass the 2 x cables through the elbow. (It is important to have the first outer insulation cover removed 200mm back exposing the 3 x insulated wires, as passing the complete cable through the elbow is very tight).

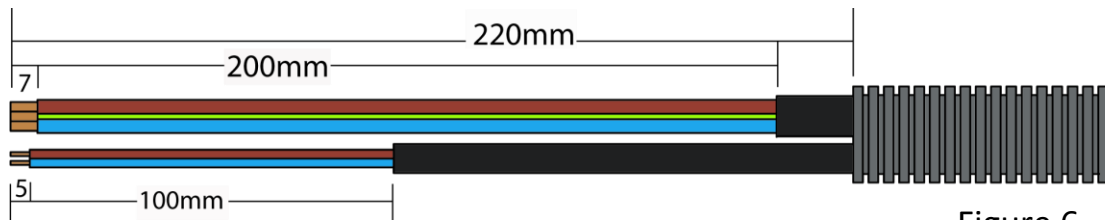

Figure 6.

3. Terminate the element positive, negative & earth as per the instruction label that is affixed to the inside of the element enclosure cover and per the labelled colour coded connection points within.
4. Connect the 2 x colour coded NTC sensor wires into colour coded mounting block.

See Figure: Wiring Diagram - PV OTC - Element

5. Ensure PVOTC which is spring located onto vessel surface has not been disturbed during installation and is sitting in place and secure.
6. Using the supplied cable saddles and removing and replacing base lid screws to fit saddles, secure supply cable securely to the base of the hot water tank.
7. Refit lower DC element cover.

PVOTC is only activated by overheating of the storage vessel which indicates a potential system fault. The PVOTC is a onetime operation and is NON RESETTABLE. Sacrificial fuses must not be replaced at any stage, if activated the PVOTC will need to be replaced.

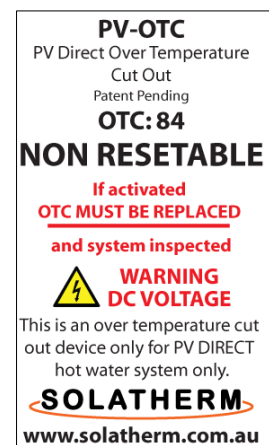

Wiring Diagram - PVOTC - Element

PVOTC is only activated by overheating of the storage vessel which indicates a potential system fault. The PVOTC is a onetime operation and is NON RESETTABLE. Sacrificial fuses must not be replaced at any stage, if activated the PVOTC will need to be replaced.

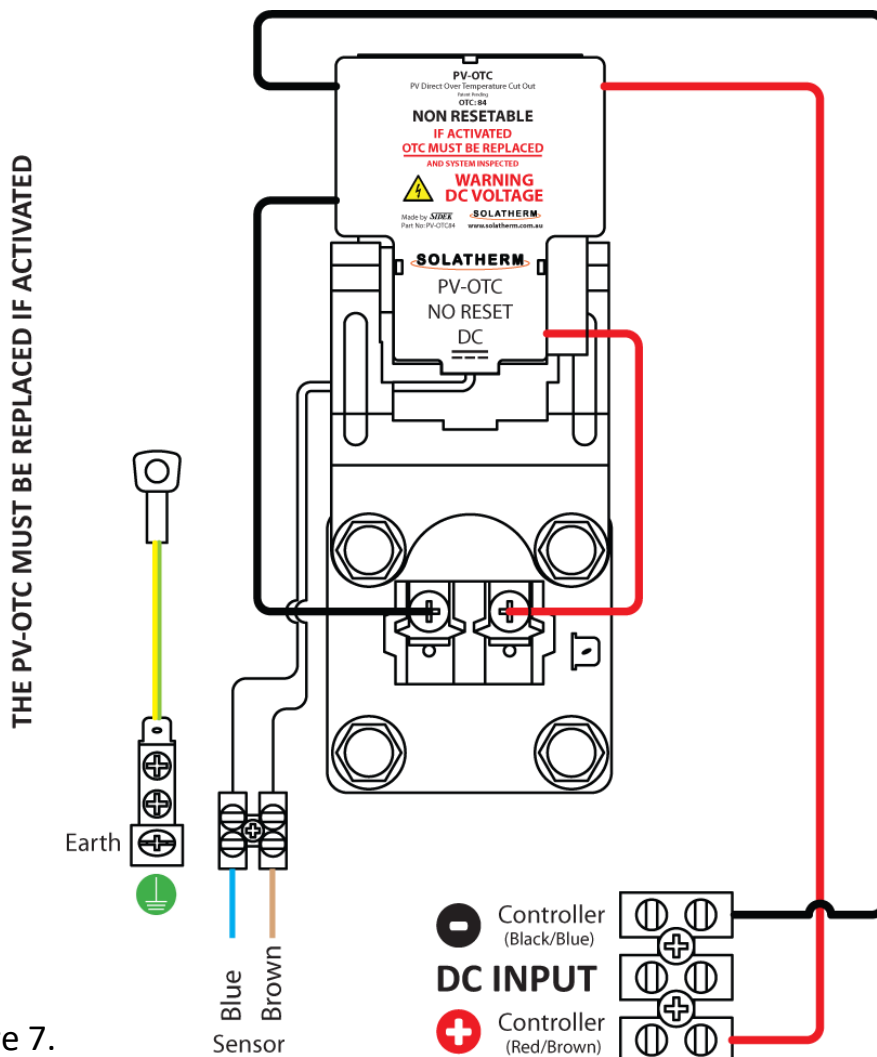





Figure 7.

All electrical work and permanent wiring must be carried out by a qualified person and in accordance with standards AS/NZS 5033, AS/NZS 3000 and local authority requirements.

-  **PV Direct system must not be operated without the PV-OTC connected**
-  **WATER HEATER MUST BE CONNECTED TO EARTH**
-  **Operation of the thermal cut out is an indication of a system fault. The system must be checked before OTC is replaced**
-  **Never connect power to an empty water heater.**

See instruction manual for full installation details or www.solatherm.com.au
Thermostat cover must be installed at all times. Conduit glands must be sealed.

Connection - Main Array Input

1. Terminate cables with MC4 Connectors. Connect the cable to the Isolator. Ensure Polarity on the MC4 connections is correct. TEST the polarity at the MC4 connectors **BEFORE CONNECTION TO THE CONTROLLER**. Ensure to connect the earth from the controller to the earth point from the main array frame within the Isolator. Earth from controller and Array must be connected to house ground point.

See Wiring Diagram - Controller - Figure 3

2. Test voltage from array. Confirm correct for controller model and cylinder element.
3. Connect MC4 Connectors to controller input only when ready to commission - See Commissioning Start up pg 19.

Ensure polarity at the MC4 connectors is correct before proceeding further. TURN ISOLATOR ON AND TEST CORRECT POLARITY TO CONFIRM BEFORE PROCEEDING.

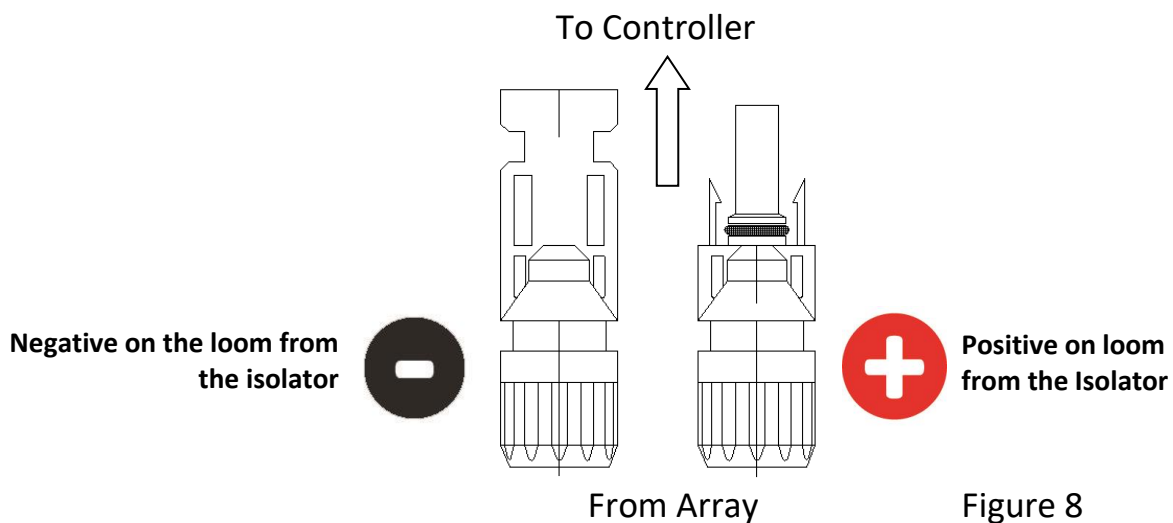

Figure 8

IT IS IMPORTANT TO ENSURE THAT THE SUPPLY FROM THE MAIN ARRAY IS TERMINATED POLLARITY CORRECT AND MUST BE CHECKED BEFORE CONNECTION!!

**THE CONTROLLER WILL BE DESTROYED IF REVERSE POLARITY CONNECTED!!
Incorrect polarity will void the warranty.**

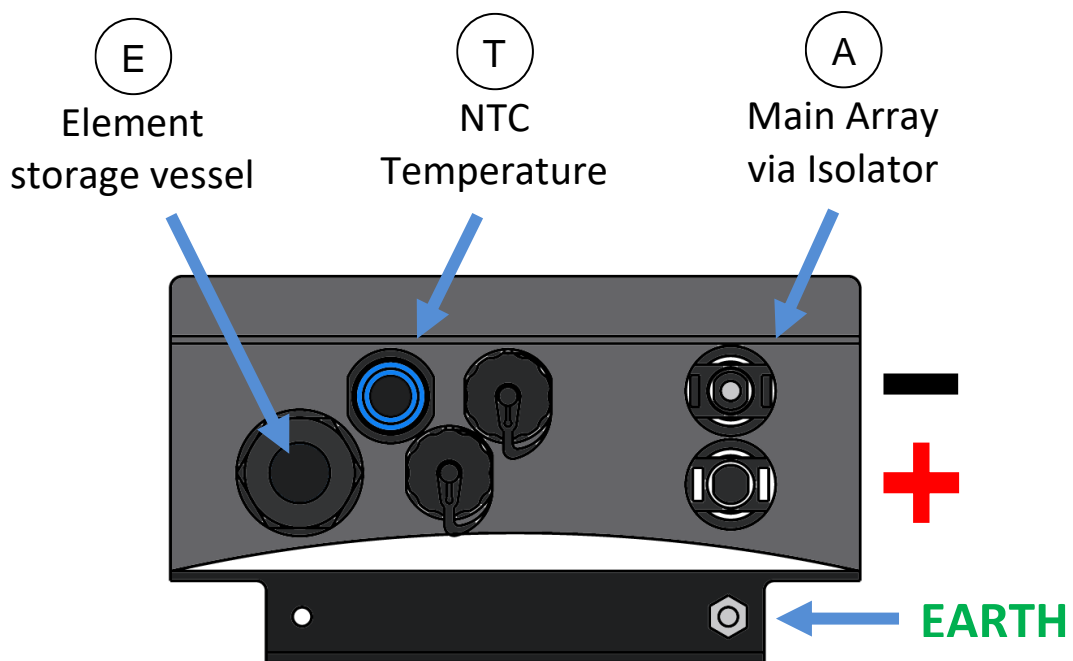

Figure 9.

Connection - Boost Element - AC

The 240V A/C Booster supply cable must be installed in accordance to Australian Standard AS3000 and by a qualified person.

Note: Never energise the element until the water vessel is filled and bled!

1. Remove top booster 240V A/C element cover.
2. Connect into the 25mm female elbow using 25mm flex conduit and approved twin and earth cable suitable for the booster element fitted.
3. Following the wiring instructions affixed inside the cover, (The standard booster element is 2.4Kw 10Amp but this may vary depending on application ensure to identify and wire to suit load).

The hot water vessel must be connected to Earth.

****Note****

Consideration must be given to the local power supply offerings to maximise operation of the PV solar contribution. E.g.: In locations where a controlled load (off peak) is available the booster supply ideally should be connected to this tariff. In locations where only peak supply power is available, it is recommended to fit an A/C supply timer which can be set to the individual requirements of the end user.

ON THE ROOF

The main array must be installed to Australian standards and all relevant local authority requirements by a authorised installer. Consideration must given to the position of the isolator in relation to the final controller position. The main array must be earthed with the earth cable into the isolator.

Panel Configuration

The PV controller is designed to operate with a matched number of PV panels and strung as 2 x strings of 3, 4, 5 or 6 panels per string depending on the model and DC element. The supply from the main array must be tested and identified to be strung correctly with the correct number of panels to suit the matched controller and element. See table 1 below and controller data spec sheet to identify model fitted. Terminate main array into isolator testing and ensuring **TERMINATED POLLARITY IS CORRECT**. The controller will show fault and not engage where 270 Volts is exceeded.

CROSSED CONNECTION WILL RESULT IN FAILURE OF THE CONTROLLER!
Damage to reversed polarity connection will not be covered by warranty

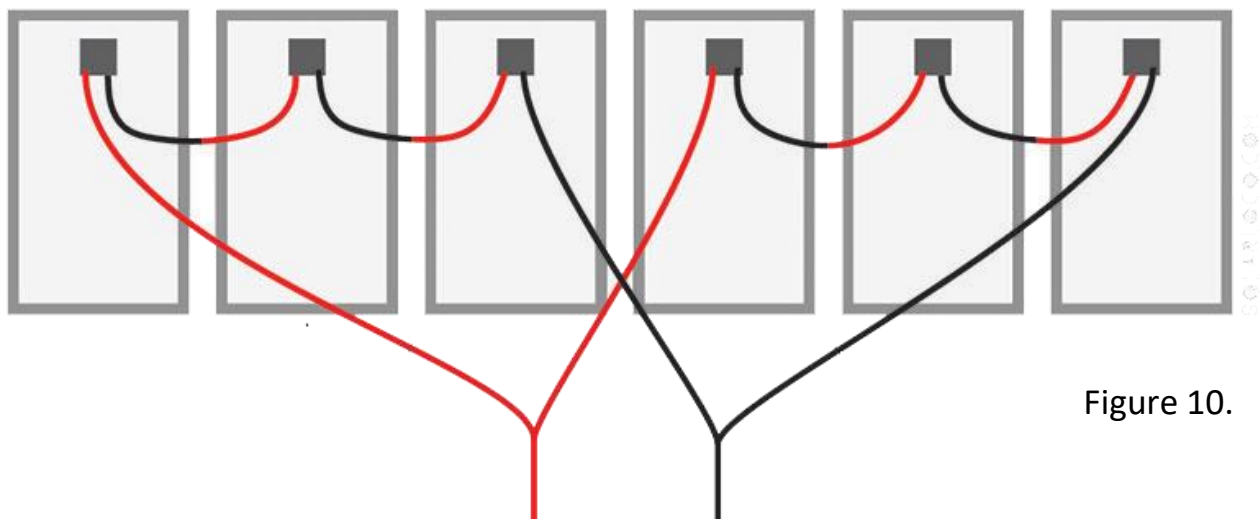

Figure 10.

Commissioning Start Up

1. Ensure polarity at the MC4 connectors is correct before proceeding further.

TEST CONNECTORS BEFORE CONNECTION INTO THE CONTROLLER (PCE)

2. TURN ISOLATOR ON AND TEST CORRECT POLARITY TO CONFIRM BEFORE PROCEEDING. Figure 11.

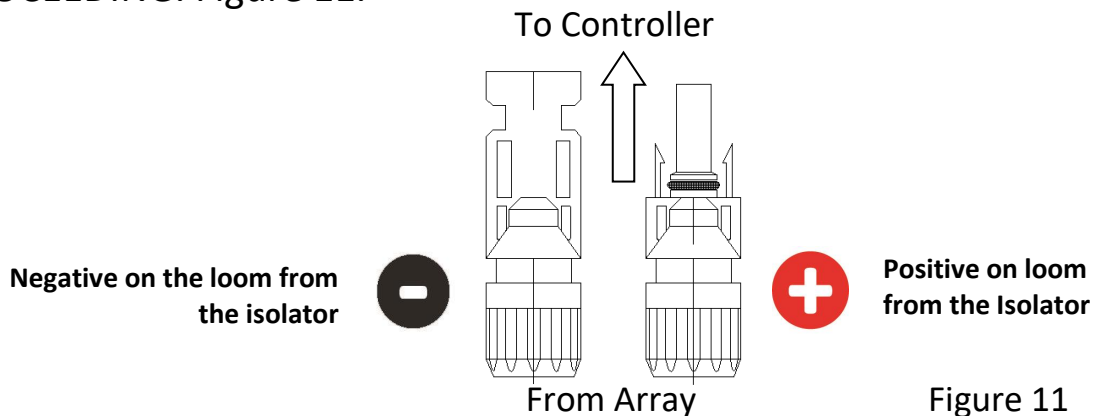

Figure 11

3. Test voltage from array. Confirm correct for controller model.
4. Connect MC4 connectors to control unit.
5. Ensure all cables are terminated as per installation instructions.
6. Turn on isolator.
7. RED LED POWER LIGHT SHOULD BE ON. The controller should show start up information as it runs through a power up test sequence. When test is complete LCD will display system voltage etc. (providing array voltage is over 40 Volts)
8. After the start up sequence is complete the green heating LED will light up if sufficient power is available to commence heating. Note: The controller has several built in time delays of up to 1.5 minutes, to allow for power stabilisation. Some models will start on divert for 30min prior to heating. See supplement.
9. Turn on 240V AC booster isolator and breaker switch in household fuse box.
10. Test and record data on the Commissioning sheet in this booklet and make a copy for submission to Solatherm. Form A

Shut down Procedure

1. Turn off main array Isolator (lock switch if required)
2. Controller should now have no information displayed and is OFF.
3. Turn off 240V AC Booster Isolator and breaker switch in household fuse box.

Warranty

Solatherm PV360 Controller

The warranty covered by this document is for the Solatherm control unit and directly related components specified below only. For warranty on other items that are part of the system, such as, installation components, storage water vessel and photovoltaic collectors, please see the relevant manufactures warranty booklet.

Domestic ⁽¹⁾	Controller	5 Years Replacement from date of installation
	Labour	1 Year
	Components ⁽³⁾	1 year
Commercial ⁽²⁾	Controller	3 Years Replacement from date of installation
	Labour	1 Year
	Components ⁽³⁾	1 year

This booklet must be fully completed and retained with proof of purchase and all COC's for warranty.

Warranty Definitions

Our goods come with guarantees that cannot be excluded under the Australian Consumer Law. You are entitled to a replacement or refund for a major failure and compensation for any other reasonably foreseeable loss or damage. You are also entitled to have the goods repaired or replaced if the goods fail to be of acceptable quality and the failure does not amount to a major failure.

(1) Domestic usage is defined as a single family domestic home with a setting of less than 75°C. (2) Commercial encompasses all other applications. (3) Components include dedicated DC heating element, PV Over Temperature Cut Out & temperature sensor

Warranty Conditions

1. Installation must be undertaken by licensed installers; photovoltaic accredited Electrician, licensed plumber and must be in conformance with all installation instructions supplied with the system and must conform with all regulatory and statutory requirements relevant to the state where the system is installed.
2. Proof of Purchase must be retained by the owner as this will be required should any warranty work need to be carried out on your system.
3. The option to replace or repair a failed component is at the sole discretion of Solatherm.
4. Where any part is repaired or replaced the duration of the original warranty period is still applicable. The repaired or replacement component does not carry a new warranty.
5. The warranty only applies directly to the Solatherm control unit and directly related parts as specified not to other general plumbing or electrical components used during installation or to meet regulatory requirements. The main photovoltaic array collectors and storage water vessel will have their own manufacturers warranties which are separate to this document
6. Systems installed outside of the metropolitan area may be subject to freight costs and additional labour costs.

7. The system installed must be sized in accordance with manufacturers guidelines.
8. Any repair under warranty must be approved by Solatherm prior to the repair or all costs are bore by the person who contracted the repair.

Warranty Exclusions

The following exclusions may cause the Solatherm warranty period to become invalid and/or may incur a service charge and/or cost of parts used during repairs.

1. Accidental damage to the Controller or any component including; Acts of God, failure due to misuse, incorrect installation, unauthorised attempts to repair the system.
2. Where there is nothing wrong with the control unit and the problems relates to incorrect installation or abnormal conditions such as incorrect array configuration or reverse polarity and or faulty electrical connection.
3. Where the unit is not installed according to Solatherm installation instructions.
4. Where there are claims for damage to walls or any other installation damage directly or indirectly related to the installation of the system.
5. If the enclosure has been opened all warranty is void.
6. If the commissioning form is not completed or filled out incorrectly warranty is void.
7. COC's must be completed, signed and available for verification. Non compliant installations will void warranty.

Warranty Contact

Solatherm / Sidek Manufacturing Pty Ltd
1/52 Barnett Ave
Glynde SA 5070
E: warranty@solatherm.com.au
T: 1300 965 948

Commissioning

System Information - Form A

Owner's Name			
Installation Address			
Suburb	State	Post Code	
Telephone	M:	E:	
System Purchased from			
Installer's Name		Installation Date	
Contact Number		CEC Number	
Job Number			
Type of Installation	New	Replacement	Unit Type Replaced

DC PV Hot Water Controller

Controller Model	Serial Number
All Output Connections terminated	Y/N
Cylinder Full of Water?	Y/N
Storage Cylinder Earthed?	Y/N
VOC at Isolator	V Is DC Voltage with in operating limits of the controller? Y/N
Energise Main Array, System initialises?	Y/N
Voltage on Display	V Watts Shown W
Heating light on?	Y/N
Power as expected?	Y/N

Boost Element

AC Boost Element connected?	Y/N
AC Voltage	V AC Current A
Does Booster Energise ?	Y/N

Main Array - On the roof

No. Of Collectors		No. Of Strings	
PV Collector Brand		PV Collector Model	
Collector Size (Watt)		System Voltage Shown	
PV Array Azimuth		PV Array Pitch	
PV Array Total		DC Isolator Type	
DC Cable size		Array Earthed?	Y/N

Main Array (On the Ground)

Polarity Main Array at Isolator Correct	Y/N
WARNING INCORRECT POLARITY WILL DAMAGE THE CONTROLLER - NO WARRANTY FOR POLARITY DAMAGE	

Does The Array have any Shading?	Y/N
Is the Array installed to AS5033 and CEC Guidelines?	Y/N
Is the controller switch gear and cabling installed to AS3000 and CEC guidelines?	Y/N
Are all serial numbers recorded	Y/N
Are all labels installed as per AS4777.1	Y/N
Have all roof tiles/iron sheets been re-installed?	Y/N
Have all the required customer signature fields been signed?	Y/N
Is the array installed as per installation advise form? (Form 2)	Y/N
If not describe why?	

Installer Certification I hereby certify that this system has been installed according to all relevant regulatory and statutory requirements and in accordance with Solatherm Installation Instructions.

Name

COC Accreditation
Number

Signature

Date

Owner Declaration

I have received the installations booklet and owner manual Y/N

The system has been installed at the above property and all customer details are correct. I am happy with the installation quality and approve the location of the solar equipment. I am satisfied that the roof is suitable to accommodate the array over the life its intended.

Signature

Date

This booklet must be fully completed and retained with proof of purchase and all COC's for warranty.

System Diagram

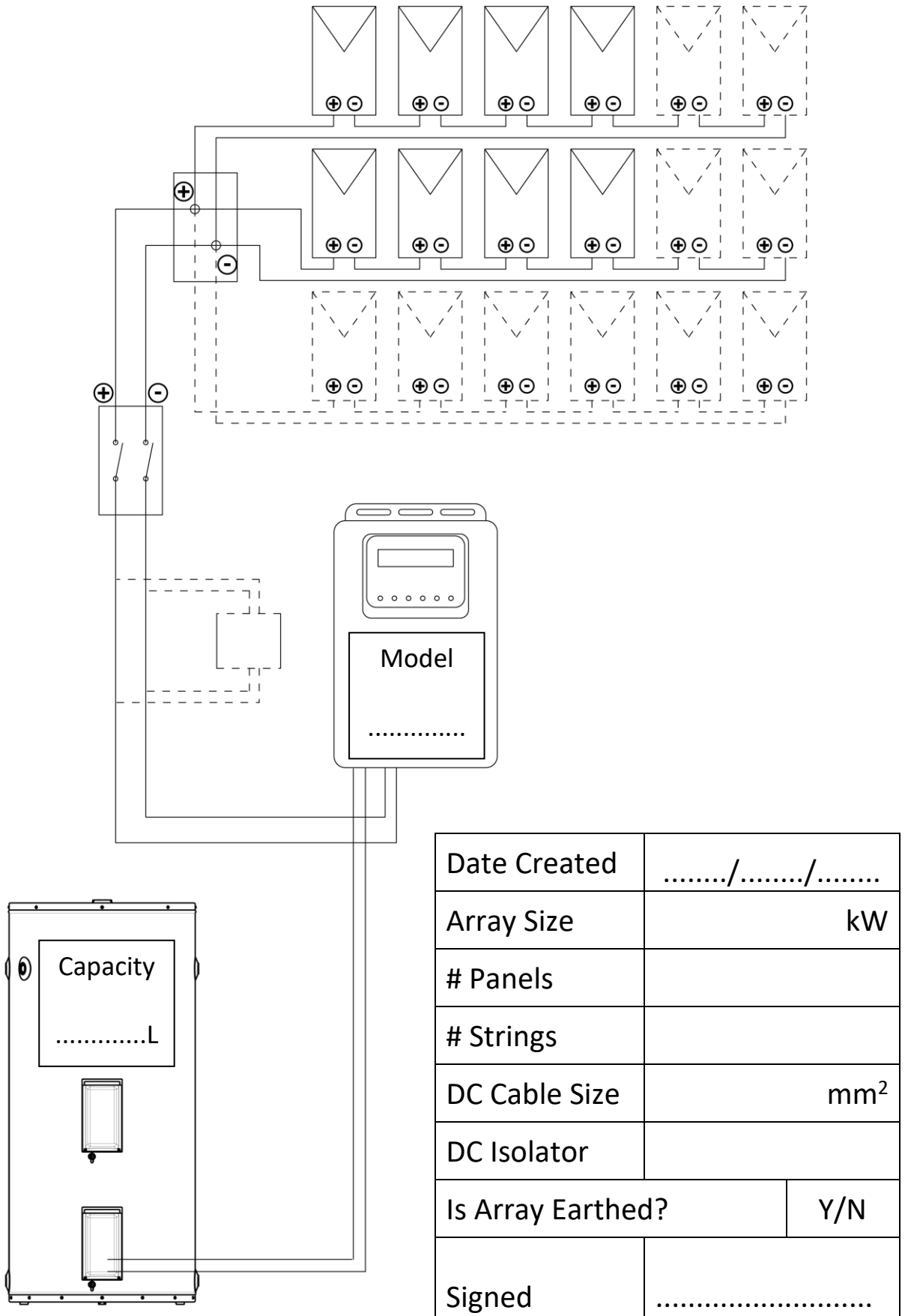

This diagram must be fully completed and retained with all COC's for service personnel.

Technical Data

PV String Input Data			
Max. DC Input Power	3.84 kW	Array Strings	2
Max. DC Input Voltage	270 VDC	String Configuration	Parallel
Max. Input Current	22.0 A	Max DC Voltage Output	270VDC
Max. Output	3.84 kW	Max. Output Current	22.0 A
Input Reverse Polarity Protection	NO	Input Over Voltage Protection	YES
Max power must not be exceeded. 3.84kW can be either 270V @14.2A or 174V @ 22.0A or in between. P=IR (Volts x Current), 3840W must not be exceeded.			

General Data			
Operating Temp. Range	-20°C to + 50°C	Dimensions (H*W*D)	220x145x70 mm
Relative Humidity	0-100%	Protection Degree	IP65
Operating Altitude	< 4000m	Safety Regulation	IEC 62109
Cooling	Natural Convection	Pollution Degree	PD2
Weight	2.3 kg	Overvoltage Category	OVC II
Environment	Outdoor	Location Classification	Suitable for Wet areas
Heating Start Power	250 W	Factory Set Shut temp	60°C or 70°C
User Interface	LCD & LED Indication	Country of Manufacture	Australia

Supplied Cabling Data			
Main Array Cable	MC4 Connection	NTC Cable	2 x 0.75mm ²
Element Cable	3 x 4mm ²	Cable Insulation	Flex Rubber UV Stable
Insulation Type	Flex PVC UV Stable	Insulation Rating	0.6/1kV
Conduit	25mm OD x 19mm ID UV Stable PV Approved		

Nominal Single Panel Data			
Nom. Panel Voltage VOC	44 V Max.	Nom. Max. Power Voltage (V)	32.5 V
Short Circuit Current I _{sc}	11.0 A Max.	Max. Power Current (A)	11.0 A

Array Size to match element configuration	Element - Nominal Output	
Nominal Input 1.7kW - VOC 114 V 2 strings of 3 panels = Total 6 panels	2S3P	1460 W
Nominal Input 2.3kW - VOC 152 V 2 Strings of 4 panels = Total 8 panels	2S4P	1940 W
Nominal Input 2.9kW - VOC 190 V 2 Strings of 5 Panels = Total 10 panels	2S5P	2645 W
Nominal Input 3.5kW - VOC 230 V 2 Strings of 6 Panels = Total 12 panels	2S6P	3240 W